



## **SINGLE Bottle EFI Motorcycle Applications**

CONGRATULATIONS on purchasing your DynoTune Nitrous Oxide Injection System! Your system is composed of the highest quality components available. It should provide many miles of trouble-free performance when used correctly. If you have any questions regarding the performance of our system, call DynoTune Technical Service at 1-978-562-6040.

**NOTICE:** Installation of this DynoTune INC. Nitrous oxide system product signifies that you have read this document and have agreed to the terms stated within.

It is the purchaser's responsibility to follow all installation instruction guidelines and safety procedures supplied with the product as it is received by the purchaser to determine the compatibility of the product with the bike or the equipment the purchaser intends to install the product on.

DynoTune assumes no responsibility for damages occurring from accident, misuse, abuse, improper installation, improper operation, lack of reasonable care, or all previously stated reasons resulting from incompatibility with other manufacturers' products.

DynoTune neither recommends nor condones the use of products manufactured or sold by DynoTune in vehicles, which may be driven on public roads or highways, and assumes no responsibility for damages incurred by such use. This kit is for off road use only!

DynoTune nitrous oxide is legal for use in most states when used in accordance with state and local traffic laws. DynoTune does not recommend or condone the use of its products in illegal racing activities.

DynoTune has not pursued California Air Research Board (CARB) exemptions for this kit, hence, they are not legal for use on pollution-controlled bikes in California. A correctly installed DynoTune nitrous system should not alter the emission control performance of your vehicle under standard EPA test cycle conditions.

### **HAZARDS DEFINED**

This manual presents step-by-step instructions that describe the process of installing your DynoTune Nitrous Oxide Injection System. These procedures provide a framework for installation and operation of this kit. Parts are referenced by name and number to avoid confusion. Within the instructions, you are advised of potential hazards, pitfalls, and problems to avoid. The following examples explain the various hazard levels:

**WARNING!** Failure to comply with instructions may result in injury or death

**CAUTION!** Failure to comply with instructions may result in damage to equipment.

**NOTE:** This information is important, needs to be emphasized, and is set apart from the rest of the text.

**HINT:** These special instructions provide a handy work tip.

## NITROUS OXIDE INJECTION SYSTEM SAFETY TIPS

### WARNINGS

- ❑ Do not attempt to start the engine if the nitrous has been injected while the engine was not running. Disconnect the coil wire and turn the engine over with the throttle wide open for several revolutions before attempting to start. Failure to do so can result in extreme engine damage.
- ❑ Never permit oil, grease, or any other readily combustible substances to come in contact with cylinders, valves, solenoids, hoses, and fittings. Oil and certain gases (such as oxygen and nitrous oxide) may combine to produce a highly flammable condition.
- ❑ Never interchange or modify system components. Failure to follow these simple instructions can result in extreme engine damage and/or personal injury.
- ❑ Never drop or violently strike the bottle. Doing so may result in an explosive bottle failure.
- ❑ Never change pressure settings of safety relief valve on the nitrous bottle valve. Increasing the safety relief valve pressure settings may create an explosive bottle hazard.
- ❑ Identify the gas content by the Dynotune on the bottle before using. If the bottle is not identified to show the gas contained, return the bottle to the supplier.
- ❑ Do not deface or remove any markings, which are on the nitrous bottle.
- ❑ Nitrous bottle valves should always be closed when the system is not being used.
- ❑ Notify the supplier of any condition, which might have permitted any foreign matter to enter the valve or bottle.
- ❑ Keep the valves closed on all empty bottles to prevent accidental contamination.
- ❑ After storage, open the nitrous bottle valve for an instant to clear the opening of any possible dust or dirt.
- ❑ It is important that all threads on the valves and solenoids are properly mated. Never force connections that do not fit properly.

## TABLE OF CONTENTS

### WHAT IS NITROUS OXIDE?

#### Do's and Don'ts of Nitrous Oxide

#### Chapter 1. Introduction to your DynoTune Nitrous Oxide Kit

#### Chapter 2. Kit Installation

#### Chapter 3. Baseline Tuning Suggestions

#### Chapter 4. Preparing for Operation / Filling your bottles

#### Chapter 5. Advanced Tuning for Maximum Power

#### Chapter 6. Routine Maintenance

### WHAT IS NITROUS OXIDE?

#### Nitrous Oxide ...

... Is a cryogenic gas composed of nitrogen and oxygen molecules.

... Is 36% oxygen by weight.

... Is non-flammable by itself

... Is stored as a compressed liquid

... Exists in two grades --- U.S.P. and Nitrous Plus:

- ❑ U.S.P. is medical grade nitrous oxide; its common use is dental and veterinary anesthesia. It is commonly used as a propellant in canned whipped cream. U.S.P. is not available to the public.
- ❑ Nitrous Plus differs from U.S.P. in that it contains trace amounts of sulphur dioxide added to prevent substance abuse. Nitrous Plus is intended for automotive applications and is available for sale to the public.

In Bike applications, Nitrous is injected into the engine's intake manifold, which produces the following results:

- ❑ Lowers engine intake air temperature, producing a dense inlet charge.
- ❑ Increases the oxygen content of the inlet charge (air is only 22 percent oxygen by weight).
- ❑ Increase the rate at which combustion occurs in the engine's cylinders.
- ❑ Fools electronics into adding additional fuel to make more power.

## Do's and Don'ts of Nitrous Oxide

### Do's

- ❑ Read all instructions before attempting to install your DynoTune nitrous system.
- ❑ Make sure your fuel delivery system is adequate for the nitrous jetting you have chosen. Inadequate fuel pressure or flow will result in engine damage.
- ❑ Use 14-gauge (minimum) wire when installing electrical system components.
- ❑ Use high-quality connections at all electrical joints.
- ❑ Use Teflon-based paste on pipe-style fittings.
- ❑ Make sure your engine and related components (ignition, carburetor, and driveline) are in proper working condition. Do not use any performance chip or modified computer that advances timing more than stock.
- ❑ If nitrous is accidentally injected into the engine when it is not running, remove the engine coil wire, open the throttle, and crank the engine 10 to 15 seconds before starting. Failure to do so can result in an explosive engine failure.
- ❑ Use your DynoTune nitrous system only at wide-open throttle and at engine speeds above 4000 RPM.
- ❑ Use a high-quality fuel, as suggested in Chapter 3, Baseline Tuning Suggestions.

### Don'ts

- ❑ Engage your nitrous system with the engine off. Severe engine damage can occur.
- ❑ Modify DynoTune nitrous systems (if you need a non-stock item, call DynoTune Technical Service for assistance).
- ❑ Over tighten AN type fittings.
- ❑ Use Teflon Tape on compression fittings unless you're a qualified installer.



- ❑ Use sealant of any kind on AN type fittings.
- ❑ Allow nitrous pressure to exceed 1100 psi. Excessive pressure can cause swelling or in extreme cases failure of the nitrous solenoid plunger.
- ❑ Inhale nitrous oxide. Death due to suffocation can occur.
- ❑ Allow nitrous oxide to come in contact with skin. Severe frostbite can occur.

### PLEASE READ:

**TURNING BOTTLE ON AND OFF: TO TURN THE NITROUS BOTTLE "ON" OR OPEN THE BOTTLE, SIMPLY SCREW THE KNOB IN FULLY CLOCKWISE. TO SHUT "OFF" OR CLOSE THE BOTTLE SIMPLY TURN THE KNOB COUNTER CLOCKWISE UNTIL IT STOPS.**

# Chapter 1. Introduction to your DynoTune Nitrous Oxide Kit

## 1.1 General Information

This kit is intended for EFI motorcycle applications. The DynoTune kit was designed to work with EFI bikes that need a little extra power. 10 to 40 hp gains are typical but 80HP is the max kit capability, call Dynotune if you need more power. The factory air intake temp sensor in the intake track or air box measure air temp going into the engine to make fuel adjustments. When Nitrous is injected into the intake track or airbox it passes by the sensor cooling it off. It is critical that your bike has a "AIR TEMP SENSOR", check with your shop manual. This cold air fools the computer into thinking that its real cold out and it puts on the electronic choke adding extra fuel through the factory fuel injectors. This extra fuel is then matched up with the extra nitrous in the engine creating the extra power via more air and fuel like liquid supercharging.

Horsepower and torque increases due to these kits will vary with engine displacement and modifications. Approximate power increase estimates can be made based upon the massflow of nitrous oxide into the engine. The following table is provided to allow you to estimate the power increase you can expect for your application. DynoTune **strongly** suggests that an upper limit of about a 40hp increase in power output from your stock engine. Exceeding this can result in premature engine failure due to lack of fuel.

**Table 1. Jetting**

Kits	Nitrous Jet	Approximate Power Increase (BHP)
DynoTune EFI Bike Kit	28	15 HP
	34	30 HP
	36	40 HP

Drivability, fuel economy, and exhaust emissions should not be affected under normal (part throttle) conditions.

## 1.2 System Requirements

When used correctly, these kits should work with stock internal engine components. To ensure proper performance and engine life, the following is an absolute must:

- If the 40hp or less jet is used, 91-93 octane and stock components should be fine. If you want to go higher to say 60hp etc, you might need stronger valve springs, a stronger clutch and a new MAP.

### 1.3 Kit Components

Before beginning the installation of your DynoTune nitrous kit, compare the components in your kit with those shown in Figure 1 and listed in Table 2.

**Table 2. DynoTune Single Bottle EFI Bike N2O Parts List**

Item	Description	Quantity	P/N
1	Main tubing 10 feet	1	
2	1/16" NPT Compression tubing Fitting	2	
3	1/8" NPT compression tube Fitting	1	
4	"T" Compression fitting for tubing	1	
5	Tubing Fitting Mount (into intake)	2	
6	Tie straps	10	
7	1/8" NPT x 3AN 90 degree Fitting	1	
8	3AN Braided Nitrous Line	1	
9	N2O Bottle with pin valve	1	
10	Bottle Bracket with spare set screws	1	
11	Nitrous Solenoid	1	
12	Flare Jets	3	
13	Wire and electrical connectors	1	
14	Arming Switch	1	
15	Solenoid bracket	1	
16	Bottle mounting Brackets	1	
17	Nitrous Fill adaptor	1	
18	Not in kit	0	
19	Not in kit	0	
20	1/8" NPT X 4AN blue fitting on fill adaptor	1	

### EFI BIKE Kit



## Chapter 2. Kit Installation

### 2.1 Bottle Mounting Instructions

NOTE: Disconnect the battery ground before beginning installation.

#### 2.1.1 Bikes

Accurate calibration of your DynoTune nitrous system depends on the bottle remaining at a stable temperature. Mount the bottle away from heat sources, such as the engine compartment or exhaust system. If you mount it near the engine and the bottle pressure gets to high the solenoid may not open or you could run lean due to much nitrous being injected into the engine.

#### Bottle mounting

Mount the bottle with the valve lower than the body of the bottle. The bottle does not contain a siphon tube so in order to get the liquid nitrous out of the bottle you need to keep the valve at the lowest point.

HAYABUSA



ZX-14



Pick your orientation



Chose your bracket orientation and install the round part of the bracket into the hole. Install the fittings into the bracket, one is 90 degree for the braided line, the other hole can be plugged or a gauge installed. Use telfon tape or sealant on these fittings.

### 2.1.1 Bottle Installation

After you have determined the location and orientation of the nitrous bottle, use the following procedure to install the bottle: Use the bracket provided to help secure the bottle. If the bracket does not fit or is causing mounting issues then you need to customize the installation. Just make sure the bottle is securely mounted and cannot cause a dangerous condition. Tap the frame or use Riv-Nuts to secure the bottle brackets in place. Make sure they clear the tires and moving parts. Make sure the bottles are on the brackets to check fitment location.

**Filling the bottle:** You must unscrew the bottle from the bracket and screw on the “Bottle Fill” adaptor. This will allow you to fill the nitrous bottle at a local speed shop.

### 2.1.2 Nitrous Lines

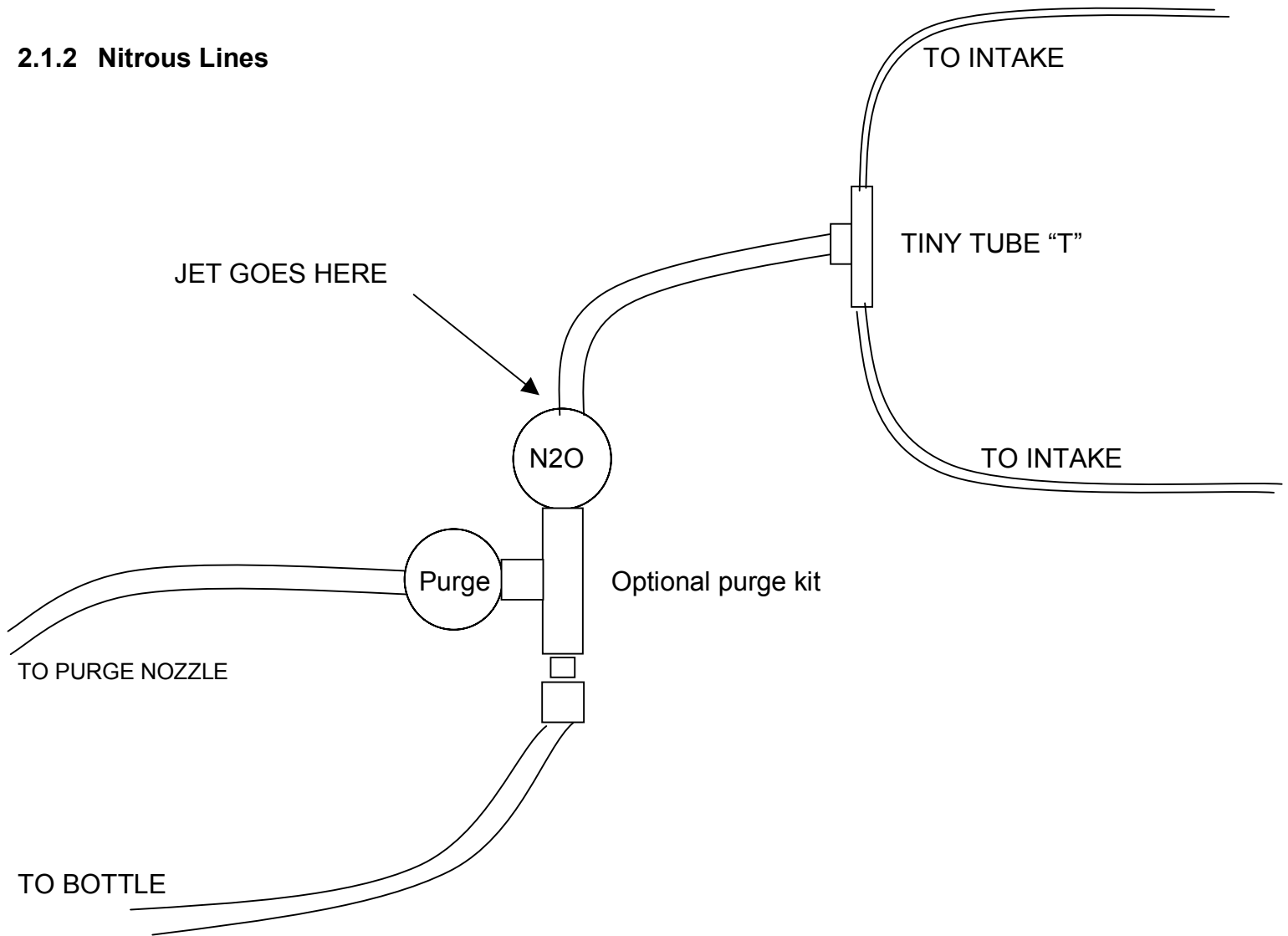

- 1) Attach the braided line to the solenoid.
- 2) If you have the optional purge, screw that assembly into the solenoid first as shown above. See pictures below for reference.





Optional billet nozzle V purge



Solenoid in the trunk

## 2.2 Solenoid mounting with jet installation

First select the jet size you want to use from the chart. Insert the jet into the solenoid “out” port as shown. Screw the compression fitting into the solenoid until it hits the jet. Do not over tighten the fitting as it can damage the jet. Just make it snug so a good seal is obtained. Shake the solenoid to make sure the jet is not rattling inside as its to lose and will cause to much nitrous to flow into the engine!!

Mount the solenoid to the bracket and secure in a cool location.



### 2.3 Nozzle fitting installation into the Air box

The goal is to get the Nitrous Cloud to spray at the air temp sensor and fool the computer. You do not want the Nitrous to miss the air temp sensor as this will cause a lean condition and make less power! The goal is to point one of the nozzles directly at the air temp sensor. Mount the first nozzle in the air box so it sprays toward the air temp sensor. Mount the other nozzle on the opposite side so they spray in a criss cross pattern. Nitrous is coming out at 900psi so it will shoot completely across the air box, so keep that in mind! You can bounce the nitrous off walls inside the air box etc. Make sure and do not mount the nozzles in a manner so that any nozzle points directly at any of the throttle body inlets. Screw in the tube fittings as shown into the mounts. Many installations do not need to use the big mounting nuts. Simply drill a tiny hole in the plastic air box and use the fitting to self tap into the plastic. A 1/16" NPT tap may be used if mounting the nozzles directly into metal like the zx-14 applications.

#### Some examples of nozzle locations



Zx-14



hayabusa

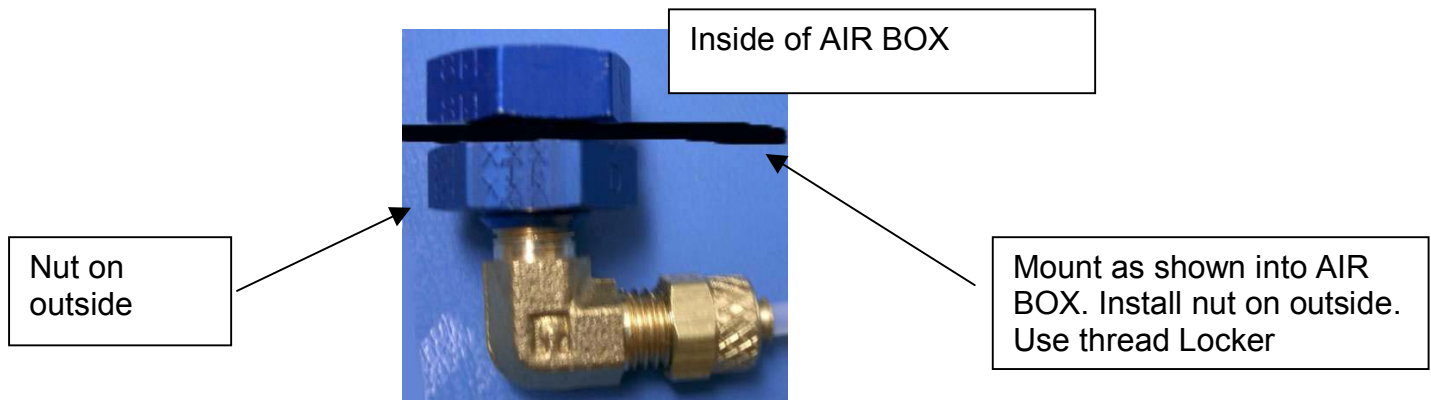

### 2.4 Tubing installation

Locate a good place for the tubing "T". Try and make the tube as short as possible from the tubing "T" to the fittings. Install the tubing into the compression fittings. Run both tubes to the "T" and install. Do not over tighten the compression fittings but tight enough so it does not pull out. Now run the tubing from the "T" to the solenoid and secure to the solenoid.

Warning! Keep away from all moving parts.

### FILLING YOUR BOTTLES

### WEAR GLOVES AND PROTECTIVE EYE GLASSES

- 1) Bring your bottle and fill adaptor with blue fitting to the speedshop Turn the knob fully counter clockwise on the fill adaptor. Attach your fill adaptor to the bottle by screwing it on.
- 2) Attached the nitrous line to the bottle(the one from the big tank). Turn the fill adaptor knob quickly fully clockwise so the pin valve on the nitrous bottle is fully depressed. (nitrous may squirt out if there is some left in the bottle so be careful!)
- 3) Open the master bottle and fill the small nitrous bottle. Crack the line at the fill adaptor to bleed the air out of the line/bottle.
- 4) Close the master bottle valve when the small nitrous bottle is full.
- 5) Quickly turn the fill adaptor fully counter clockwise (all the way out)! Nitrous will leak out a small bleed hole in the side of the fill adaptor, do not stop turning until the knob is fully counter clockwise (full out). Nitrous will continue to come out the bleed hole until all the nitrous has been bleed out of the line connecting the two bottles.
- 6) Remove the nitrous line, unscrew the fill adaptor....

## 2.5 Electrical System installation

**WARNING! Death or injury may occur from working on a charged electrical system.**

Disconnect the battery at the ground cable (if not already done.)

Your factory horn or starter(advanced installers only) switch can be used to trigger the nitrous system. The Switch is for arming the system. Use the diagrams below to help assist you with the installation.

The most common installation is the horn button. Remove the wires from the horn. Re-Route the wires up to your arming switch. Attach them to pins 2 and 5 on the switch. Use a volt meter or test light to check what wire has power on it. Make 2 new wires, with the wire provided, attach to pins 1 and 4. Run these new wires down to the horn and attach. Attach the solenoid to pins 3 and 6, no polarity on solenoids.

**Note: consult the factory shop manual for proper wiring if it is not covered in the following diagrams.**

Some models provide +12v when the horn is activated. When using wiring diagram #2 the solenoid wire polarity will need to be reversed if the horn button provides +12v.

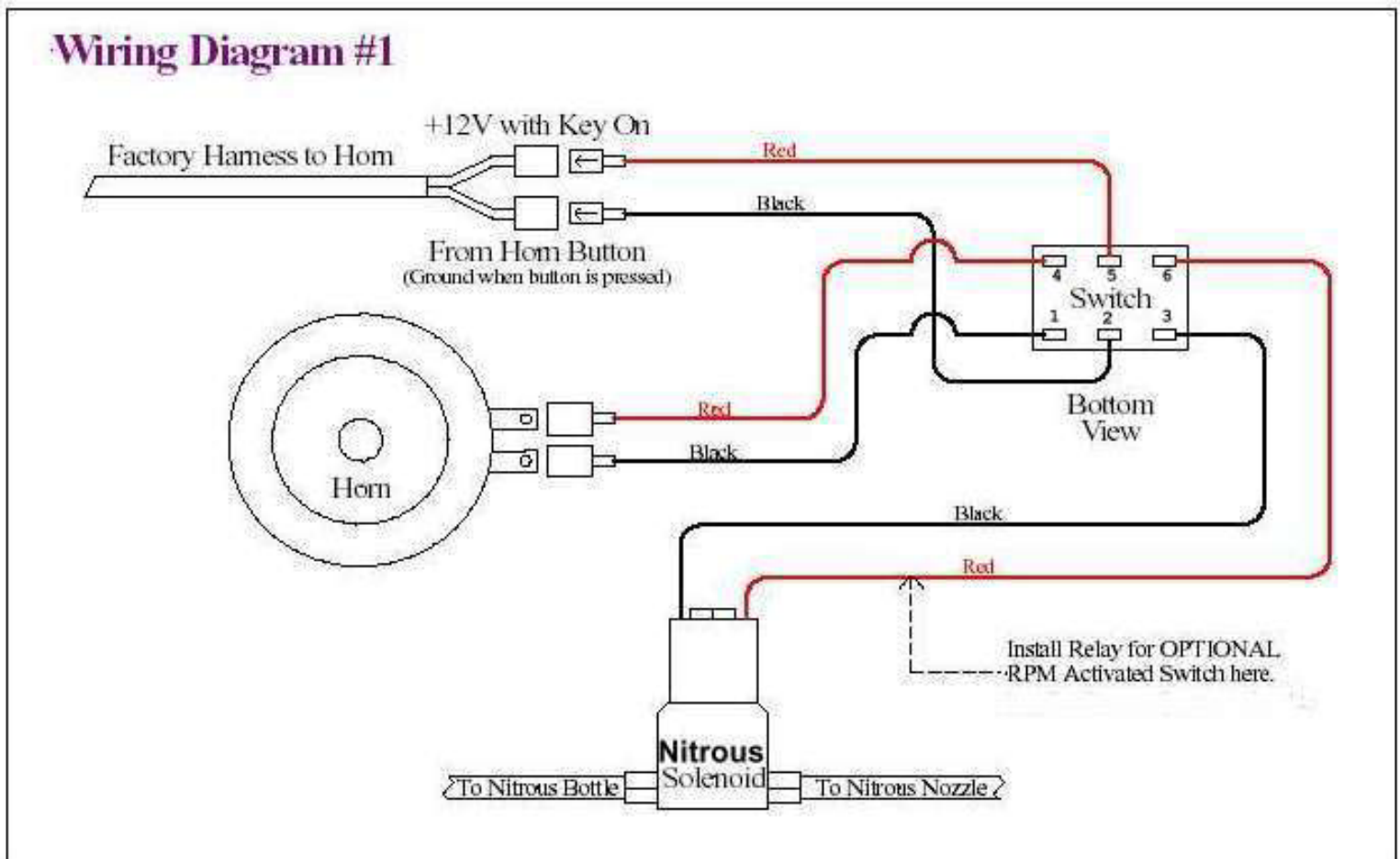

**NOTE: SOLENOIDS HAVE TWO BLACK WIRES, IT DOES NOT HAVE POLARITY SO USE ANY WIRE!**

**Factory Horn switch wire colors**

Hayabusa &amp; GSXR1000 = Solid black

ZX12R = Black with white tracer

**Factory starter switch wire colors**

Hayabusa &amp; GSXR1000 = Yellow with Green tracer

ZX12R = Blue with white tracer

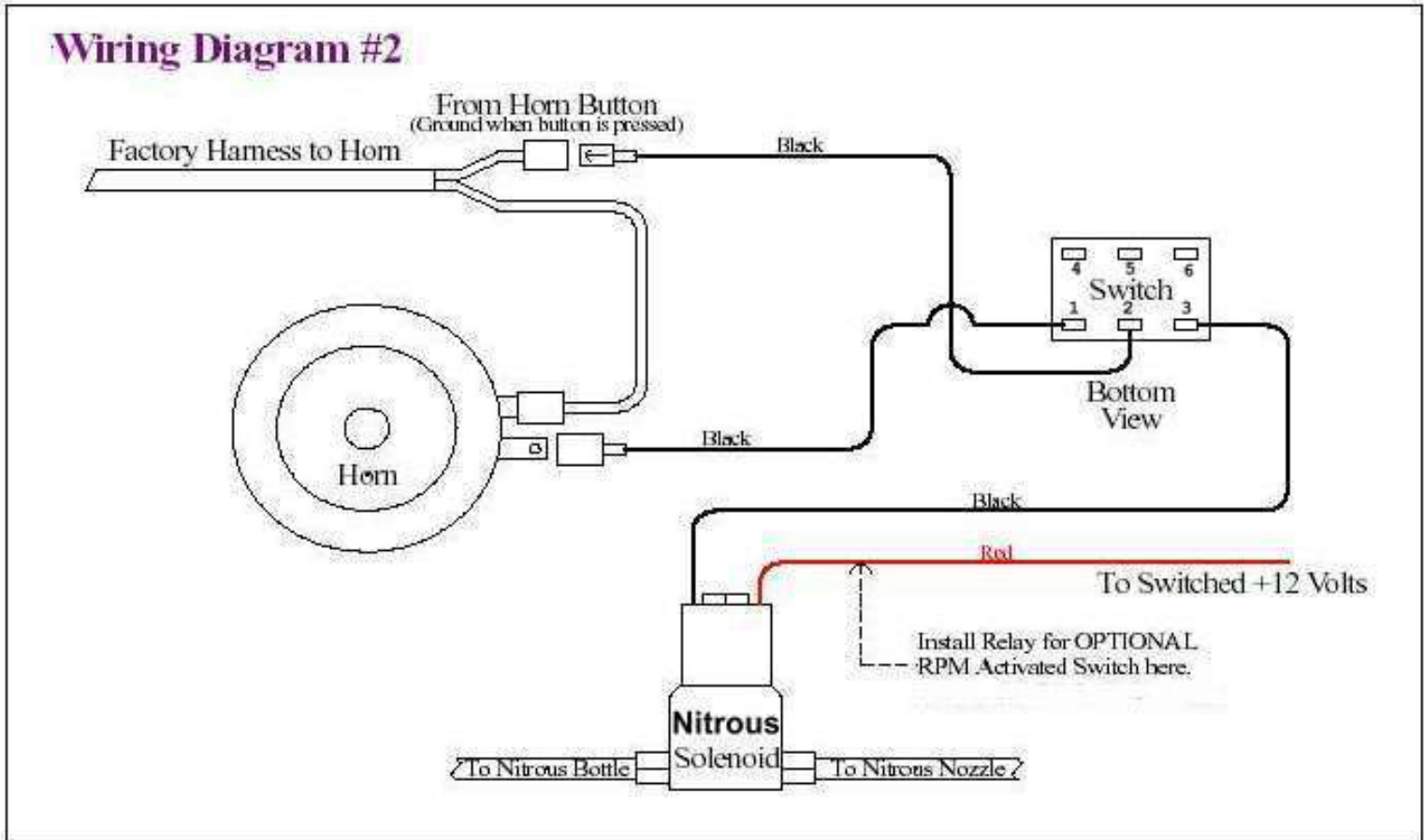

**NOTE: SOLENOIDS HAVE TWO BLACK WIRES, IT DOES NOT HAVE POLARITY SO USE ANY WIRE!**

**NOTE: Nitrous flowing through the solenoid is needed to keep the coil from melting. Short, one or two second power cycles will not hurt them but more than 5 seconds with no nitrous flowing though it will melt the coil and void your warranty.**

# Wiring Diagram #3, Starter Button Activation for Suzuki Hayabusa

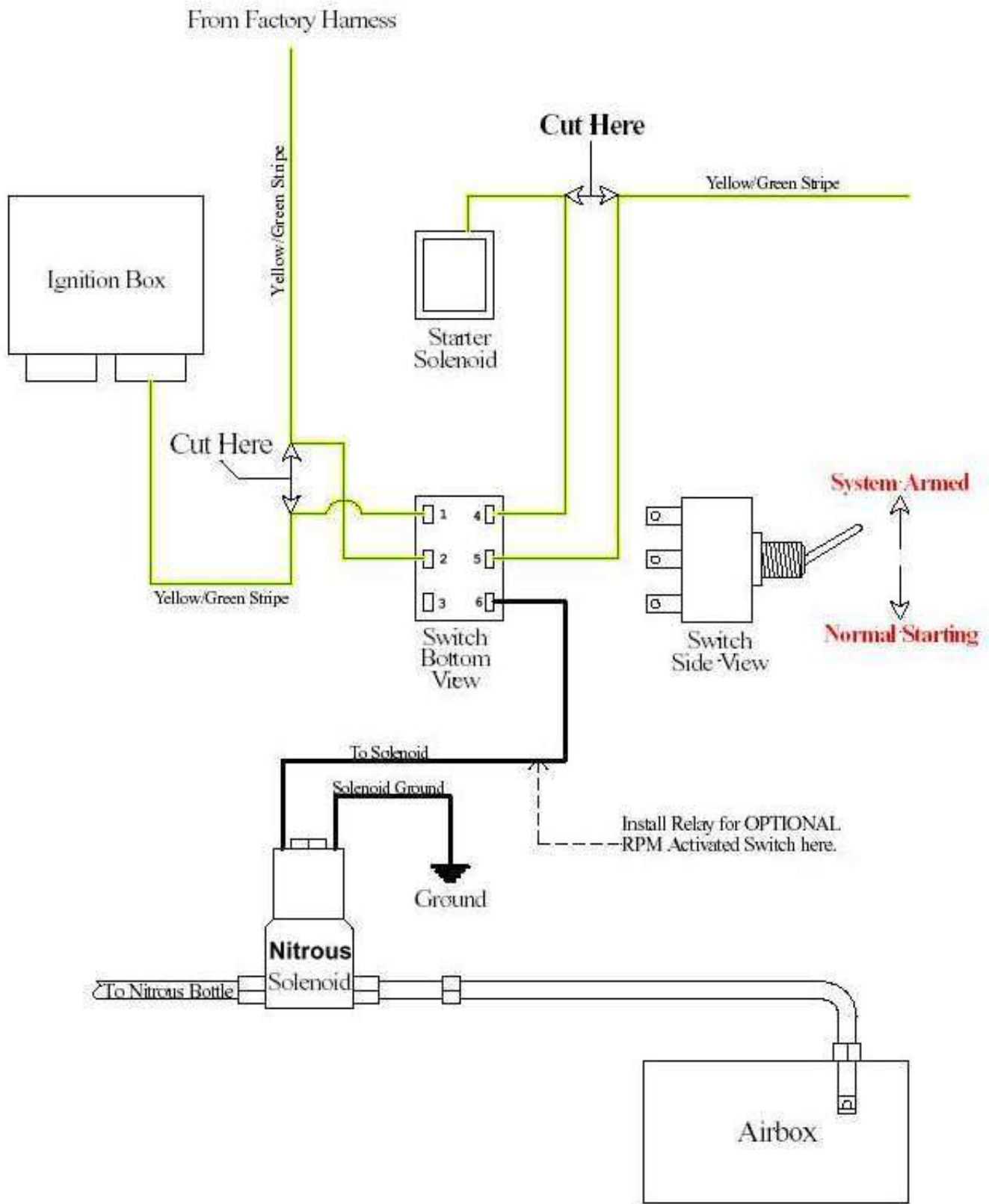

**NOTE: SOLENOIDS HAVE TWO BLACK WIRES, IT DOES NOT HAVE POLARITY SO USE ANY WIRE!**



Note: This is a suggested wiring application. There are many different ways that an optional RMP switch can be installed. The installer needs to set the RPM switch to the proper RPM and test the operation. Use wire diagrams 1&2 for relay terminal #30 connection.

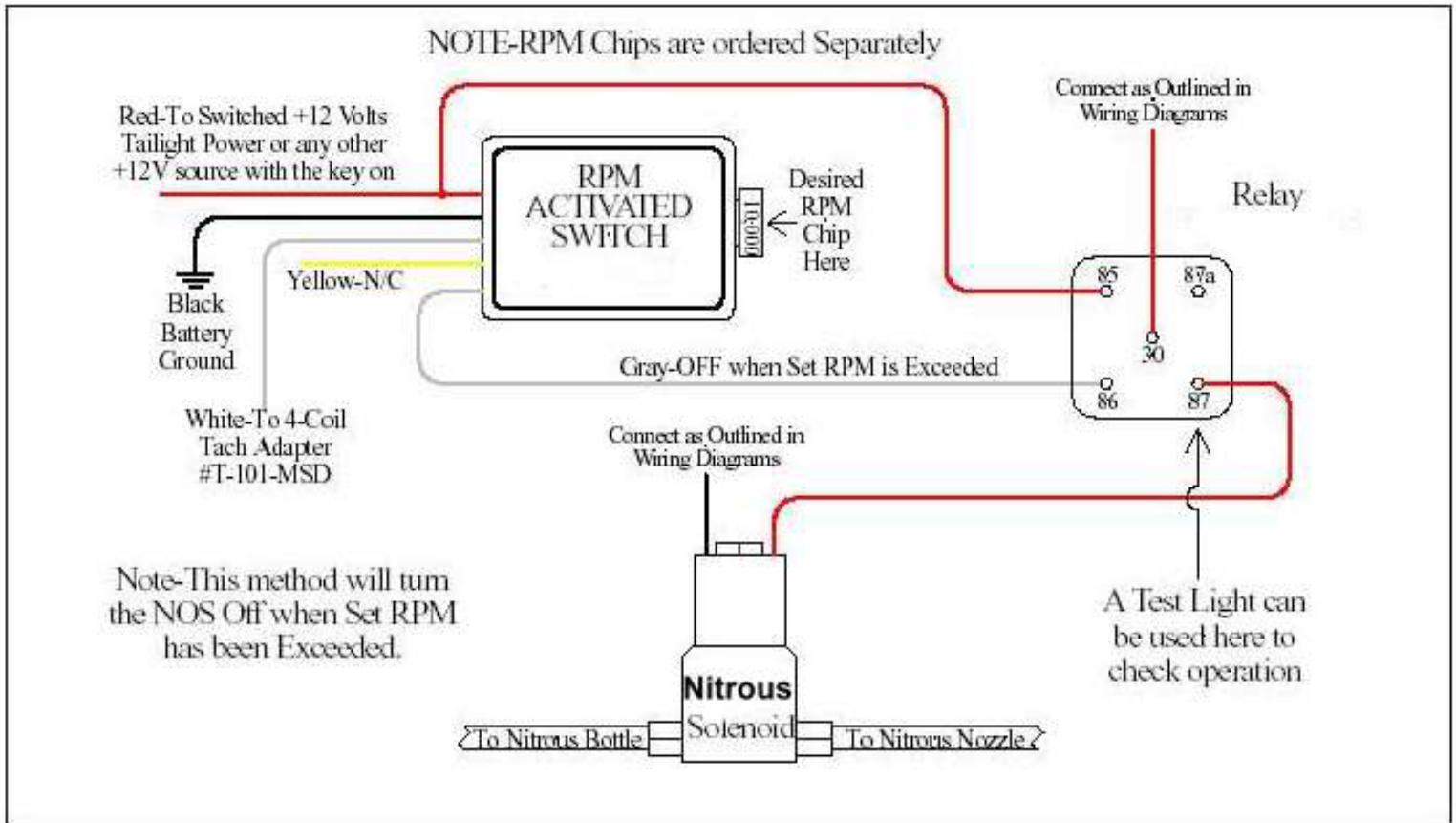

**NOTE: SOLENOIDS HAVE TWO BLACK WIRES, IT DOES NOT HAVE POLARITY SO USE ANY WIRE!**

For optional Purge installation wiring, see instructions with the Purge kit.

**NOTE: Nitrous flowing through the solenoid is needed to keep the coil from melting. Short, one or two second power cycles will not hurt them but more than 5 seconds with no nitrous flowing though it will melt the coil and void your warranty.**

### Chapter 3 Baseline tuning suggestions

Start with the smallest jet. Try it in a controlled situation like on a dyno first then on the track. Use stock timing while using the nitrous. Advancing the timing while using nitrous can lead to detonation and serious engine damage. Use the highest octane you can find, minimum 91 octane. Do not use a high than 40hp jet as this will cause engine damage. If your bike is equipped with a power commander its recommended that you increase the high rpm fuel curve to add some safety margin. Do not allow the engine to hit the rev limited while on nitrous. An rpm activated switch is great for this. Using an air shift is fine while spraying nitrous, you will get a pop out of the exhaust during shifts ,that is normal.

### Chapter 4 Preparing for operation

**Warning: Always wear proper safety gear while racing your bike. This includes, Snell or newer helmet, leather jacket, leather pants, gloves and boots that cover your ankles.**

- 1) Hook your battery back up.
- 2) Open the nitrous bottle valve (turn all the way in). Close bottle my turning knob out all the way
- 3) Inspect all the lines and fittings for leaks and adjust as needed.
- 4) Never use the nitrous in first or second gear as wheel spin or a wheelie may result.
- 5) Surging while using the nitrous is due to: 1) Nitrous in bottle is low or almost gone. 2) The nitrous is not consistently coming out of the bottle due to a poor mounting method.
- 6) Arm the system. While at Wide open throttle press the horn button to spray nitrous, let off horn button to stop spraying nitrous.

### Chapter 5 Advanced Tuning for Maximum power

After performing the Baseline Tuning Suggestion-Chapter 3, if you desire to maximize the performance of your system (40hp), Check your plugs to make sure your running safe.

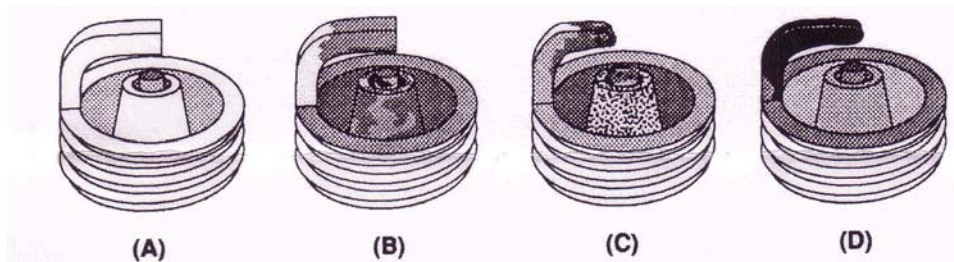

FIG. 11

#### How to read Spark plugs from a nitrous oxide injected Engine

##### A. Correct Timing, Mixture and spark plug heat range

Ground strap retains a “like new” appearance. Edges are crisp, with no signs of discoloration. Porcelain retains clear white appearance with no “peppering” or spotting.

##### B. Excessively Rich Mixture

Porcelain may be fuel stained appearing brown or black. In extreme cases, the ground strap, electrode, and porcelain may be damp with gasoline, or smell of fuel.

##### C. Detonation

Edges of the ground strap may become rounded. Porcelain has the appearance of being sprinkled with pepper, or may have aluminum speckles. During heavy detonation, the ground strap tip may be burnt off. This phenomena can result from excessive ignition timing, too high a heat range spark plug, or inadequate fuel octane.

##### D. Excessively Lean Mixture

Edges of the ground strap may become rounded. Under moderate overheating, the tip of the ground strap can discolor, usually turning purple in color, or the entire ground start can become discolored.

## Chapter 6 Routine Maintenance

### 6.1 Nitrous lines

- 1) Inspect all tubing for leaks and repair as needed.

### 6.2 Nitrous Solenoid Plunger

#### 6.2.1 General information

The seals used in DynoTune nitrous oxide solenoids are designed to be used with nitrous oxide only. When kept from fuel contamination or over pressurization, they should provide trouble free performance. You should periodically (after every 20-30 pounds of nitrous usage) examine the seal in the Nitrous solenoid plunger. The seals used in the plungers are designed to work at pressures up to 1100psi. Exposing the plunger to excessive pressure can result in the seal in the plunger swelling or in extreme cases, the plunger seal disintegration resulting in a leaky solenoid.

NOTE: The swelling of the nitrous solenoid plunger seal will reduce nitrous flow and a loss of power).

#### 6.1.1 Nitrous Solenoid plunger Disassembly and inspection

- 1) Close the valve on the nitrous bottle.
- 2) Empty the main nitrous supply line.
- 3) Remove the main nitrous supply line.
- 4) Remove the retaining nut from the nitrous solenoid and remove the coil and housing. Note any shims.
- 5) Unscrew the stem from the nitrous solenoid base. Do this by double nutting the stem; do not use pliers as this will damage the stem!
- 6) Remove the stem, spring and plunger from the solenoid base.
- 7) Examine the plunger seat for swelling. The seal surface should be flat, except for a small circular indentation in the center of the seal.

A fuel-contaminated seal will protrude from the plunger and be dome-shaped. A fuel-contaminated seal may return to its original shape if left in the fresh air over several days. A seal, which is flat, but protrudes from the plunger body has probably failed internally and should be replaced.

- 8) Re-assemble in reverse order.

