



OWNER'S MANUAL for the Deluxe Nitrous/Co2 Purge System

CONGRATULATIONS on purchasing your DynoTune Nitrous Oxide co2 purge System! Your system is composed of the highest quality components available. It should provide many miles of trouble-free performance when used correctly.

NOTICE: Installation of this DynoTune (New England Dyno and Tuning Inc.) Nitrous oxide system product signifies that you have read this document and have agreed to the terms stated within.

It is the purchaser's responsibility to follow all installation instruction guidelines and safety procedures supplied with the product as it is received by the purchaser to determine the compatibility of the product with the vehicle or the device the purchaser intends to install the product on.

DynoTune (New England Dyno and Tuning Inc.) assumes no responsibility for damages occurring from accident, misuse, abuse, improper installation, improper operation, lack of reasonable care, or all previously stated reasons resulting from incompatibility with other manufacturers' products.

DynoTune (New England Dyno and Tuning Inc.) neither recommends nor condones the use of products manufactured or sold by DynoTune (New England Dyno and Tuning Inc.), In. on vehicles, which may be driven on public roads or highways, and assumes no responsibility for damages incurred by such use.

DynoTune nitrous oxide is legal for use in most states when used in accordance with state and local traffic laws. DynoTune does not recommend or condone the use of its products in illegal racing activities.

DynoTune has not pursued California Air Research Board (CARB) exemptions for these kits, hence, they are not legal for use on pollution-controlled vehicles in California. A correctly installed DynoTune nitrous system should not alter the emission control performance of your vehicle under standard EPA test cycle conditions.

NOTICE: The DynoTune Nitrous Systems are not intended for use on hatchback type vehicles without the use of a DynoTune bottle blow-down tube kit.

HAZARDS DEFINED

This manual presents step-by-step instructions that describe the process of installing your DynoTune Nitrous Oxide Injection System. These procedures provide a framework for installation and operation of this kit. Parts are referenced by name and number to avoid confusion. Within the instructions, you are advised of potential hazards, pitfalls, and problems to avoid. The following examples explain the various hazard levels:

WARNING! Failure to comply with instructions may result in injury or death

CAUTION! Failure to comply with instructions may result in damage to equipment.

NOTE: This information is important, needs to be emphasized, and is set apart from the rest of the text.

HINT: These special instructions provide a handy work tip.

NITROUS OXIDE INJECTION SYSTEM SAFETY TIPS

WARNINGS

- ❑ Never drop or violently strike the bottle. Doing so may result in an explosive bottle failure.
- ❑ Never change pressure settings of safety relief valve on the nitrous bottle valve. Increasing the safety relief valve pressure settings may create an explosive bottle hazard.
- ❑ Identify the gas content by the Dynotune Label on the bottle before using. If the bottle is not identified to show the gas contained, return the bottle to the supplier.
- ❑ Do not deface or remove any markings, which are on the nitrous bottle.
- ❑ Nitrous bottle valves should always be closed when the system is not being used.
- ❑ Notify the supplier of any condition, which might have permitted any foreign matter to enter the valve or bottle.
- ❑ Keep the valves closed on all empty bottles to prevent accidental contamination.
- ❑ After storage, open the nitrous bottle valve for an instant to clear the opening of any possible dust or dirt.
- ❑ It is important that all threads on the valves and solenoids are properly mated. Never force connections that do not fit properly.

- ❑ Do not Use sealant of any kind on AN type fittings.
- ❑ Do not allow nitrous pressure to exceed 1100 psi. Excessive pressure can cause swelling or in extreme cases failure of the nitrous solenoid plunger.
- ❑ Do not inhale nitrous oxide. Death due to suffocation can occur.
- ❑ Do not allow nitrous oxide to come in contact with skin. Severe frostbite can occur.

Chapter 1. Introduction to your DynoTune Nitrous Oxide Kit

1.1 General Information on Purge Systems

This kit is intended for show use only, never to be used on vehicles that drive on public roads. The DynoTune co2/Nitrous purge kit is the finest purge system available. When properly installed it will send a large plum of liquid nitrous high into the air simulating a nitrous injected vehicle. Liquid is the key to a great looking purge. Make sure that your bottle is full of co2 or Nitrous oxide before you start your installation.

Kit Installation

Bottle Mounting Instructions

NOTE: Disconnect the battery ground before beginning installation.

Accurate calibration of your DynoTune nitrous system depends on the bottle remaining at a stable temperature. Mount the bottle away from heat sources, such as the engine compartment or exhaust system, and away from windows, where the bottle is exposed to direct sunlight.

Dynotune recommends that the bottle be environmentally separated from the driver's compartment. Because hatchback-type vehicles generally do not have a firewall between the trunk area and the driver's compartment, the safety pressure relief cap should be replaced with a Blow-Down kit that will vent the Nitrous outside the passenger compartment during an over pressure condition. The blow-down tube should be routed to the exterior of the vehicle (preferably under the vehicle). This procedure will prevent filling the driver's compartment with a cloud of nitrous oxide, If the safety pressure relief cap should happen to rupture for any reason.

Figure 2 Nitrous Bottle Siphon Tube Orientation

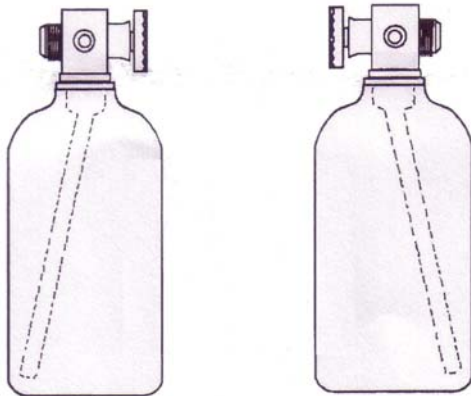
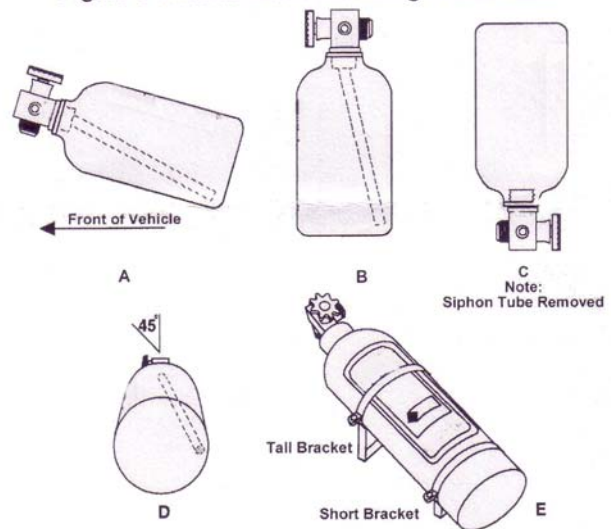

Figure 3 Nitrous Bottle Mounting Orientations



2.1 Bottle Orientation

Bottle placement is critical to the performance of your DynoTune nitrous system. It is important to understand how the bottle valve and siphon tube are assembled to properly orient the bottle in your vehicle and ensure that it picks up liquid nitrous while undergoing acceleration. All Dynotune nitrous bottles are assembled so that the bottom of the siphon tube is at the bottom of the bottle and opposite the bottle label (Figure 2).

Whenever the bottle is mounted in a lay-down position, the valve handle must be towards the front of the vehicle with the label facing up (Figure 3A).

If the bottle is mounted vertically, the label must face toward the front of the vehicle (Figure 3B). This orientation will position the siphon tube at the back of the bottle where the liquid N₂O/CO₂ will be during acceleration.

WARNING! DO NOT attempt to remove the siphon tube without completely emptying the bottle of all nitrous and pressure. Failure to completely empty the bottle will result in an explosive condition causing injury or death.

A bottle mounted upside-down must have the siphon tube removed before use (Figure 3C). Non-siphon bottles can be specially ordered from DynoTune.

If the bottle must be mounted parallel to the axles of the vehicle (sideways), the label must be angled at approximately 45° toward the front of the vehicle (Figure 3D). This orientation will position the siphon tube toward the rear of the bottle.

NOTE: When using a bottle with a siphon tube, the tall bracket should be at the valve end of the bottle and the short bracket at the bottom (Figure 3E).

The most efficient mounting is the lay-down position (Figure 3A) this position allows the greatest amount of liquid to be used before the siphon tube begins to pick up gaseous nitrous oxide.

Bottle Installation

After you have determined the location and orientation of the nitrous bottle, use the following procedure to install the bottle:

- 1) Install the bottle nut adapter (1) and Teflon washer (2) on the nitrous bottle(3). Tighten securely.
- 2) Loosely install the bottle mounting brackets(4) on the nitrous bottle, as shown below.
- 3) Locate the bottle/bracket assembly in the desired mounting location, ensuring that the location will provide easy access to the bottle valve, hose connection, and the bracket clamp bolts to facilitate bottle changing.
- 4) Use the assembled bottle/bracket unit as a pattern to mark and drill the four 5/16" holes in the mounting surface. **Caution: When Drilling or punching holes for the brackets, be aware of wires, hoses, fuel tanks etc that may be under or near the brackets!**
- 5) Mount the brackets securely to the surface.

Secure the bottle into the mounting brackets and tighten the bracket clamps.

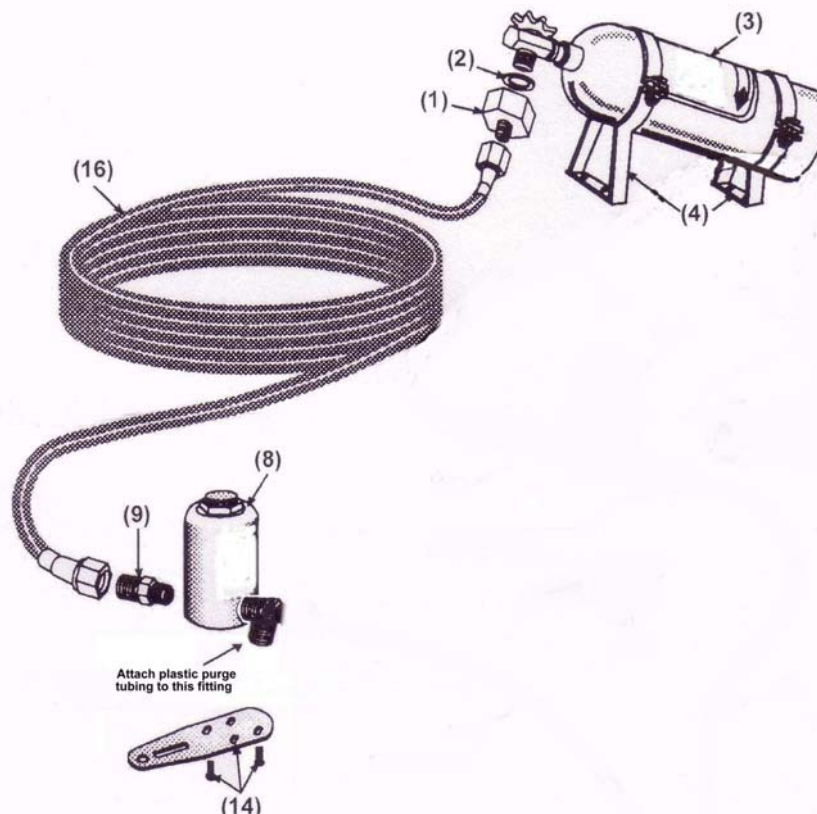

Final Installation

- 2) Attach the braided line (16) to the Bottle Nut (1).
- 3) Route the braided line from the Bottle nut to the location that you will be mounting the solenoid (8) in the engine bay. Secure the blue fitting (9) into the "IN" port on the solenoid (9). Use Teflon tape or sealer, then secure. When running the braided line its safest to run outside the car. If running the braided line inside the car, make sure it under the carpet and not running inside the open cabin. Make sure there are no kinks or sharp bends as this decreases the performance significantly.
- 4) Secure the braided line with the plastic tie warps so it does not slap around while purging, its under high pressure and can hurt you if its not properly secured.
- 5) Purge the dust out of the braided line by cracking open the bottle for a split second. Hold the end of the braided line with a rag and hold it tight! Point away from your eyes or other objects as the liquid nitrous or CO2 can burn your skin,
- 6) Attach the Braided line to the blue fitting (9).
- 7) Attach solenoid bracket and screws (14) to the bottom of the nitrous solenoid (8).
- 8) Attach the plastic purge tubing to the "out" port fitting on the solenoid. Make sure and tighten up this compression fitting so the line does not blow off! Secure all purge tubing with the tie wraps!
- 5) Wire the electrical system as shown below.
- 6) **WARNING:** Do not put power to the solenoid without nitrous/Co2 flowing through it as it will overheat and melt the coil. The Nitrous/Co2 is used to cool the solenoid! This is not covered under the warranty.

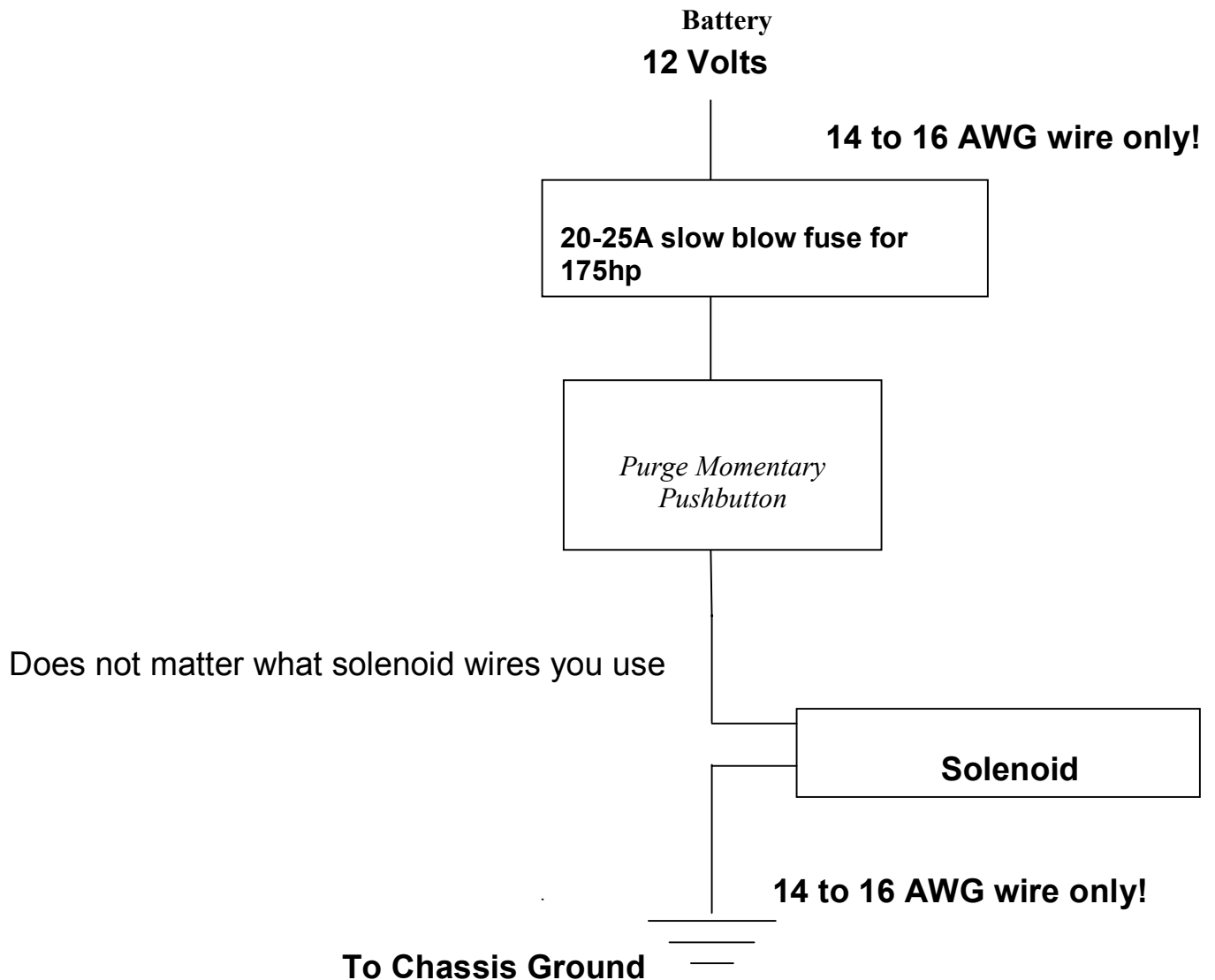

Routine Maintenance

Nitrous filters and lines

- 1) Clean the Filter in the nitrous solenoid inlet port if so equipped.
- 2) Inspect all fuel lines and nitrous lines for leaks and repair as needed.

Nitrous Solenoid Plunger

General information

The seals used in DynoTune nitrous oxide solenoids are designed to be used with nitrous oxide only. When kept from fuel contamination or over pressurization, they should provide trouble free performance. You should periodically (after every 20-30 pounds of nitrous usage) examine the seal in the Nitrous solenoid plunger. The seals used in the plungers are designed to work at pressures up to 1100psi. Exposing the plunger to excessive pressure can result in the seal in the plunger swelling or in extreme cases, the plunger seal disintegration resulting in a leaky solenoid.

Nitrous Solenoid plunger Disassembly and inspection

- 1) Close the valve on the nitrous bottle.
- 2) Empty the main nitrous supply line.
- 3) Remove the main nitrous supply line.
- 4) Remove the retaining nut from the nitrous solenoid and remove the coil and housing. Note any shims.
- 5) Unscrew the stem from the nitrous solenoid base. Do this by double nutting the stem; do not use pliers as this will damage the stem!
- 6) Remove the stem, spring and plunger from the solenoid base.
- 7) Examine the plunger seat for swelling. The seal surface should be flat, except for a small circular indentation in the center of the seal.

A fuel-contaminated seal will protrude from the plunger and be dome-shaped. A fuel-contaminated seal may return to its original shape if left in the fresh air over several days. A seal, which is flat, but protrudes from the plunger body has probably failed internally and should be replaced.

- 8) Re-assemble in reverse order.

